

ENGLISH



Compact Cooked-Rice Mixer "SHARIKKA" MCR-SSC



Turn the most delicate aspect of sushi preparation, the blending of rice and vinegar, into an automatic process that yields perfect results.

Compact Cooked-Rice Mixer "SHARIKKA" MCR-SSC

Features

- The compact design saves installation space, ideal for a small kitchen.
- Touch-panel screens enable easy operation.
- Blending method without pressure on rice enables to produce highest quality "shari" (sushi rice) just like experienced sushi chef's make.
- Three different pre-set blending programs are selectable, depending on the type and amount of rice.
- Rice can be cooled down to the appropriate temperature by a built-in blower during the blending process.
- Available for various applications; "Shari" blended with sushi vinegar, mixed rice with assorted mixtures, loosened rice in fluffier condition and etc.
- The "shari" or processed rice is easily discharged from the drum by a simple touch operation.
- Easy cleaning is possible as washable parts can be dismantled and reassembled without tools.
- Connectable to household electric outlets.

Specifications

Type

Sharikka MCR-SSC

Power

AC115V-240V, 50-60 Hz Single phase

Power consumption

95W

External dimensions

Width 496 mm (19.5 in)

Depth 589 mm (23.2 in)

Height 835 mm (32.9 in)

* The dimensions do not contain bumps and bosses.

Rice Amount Capacity

Maximum 6kg (13.2 lb) of cooked rice

Mechanism

Fully automatic

(Placing the rice into the drum is done manually.)

Dimensions

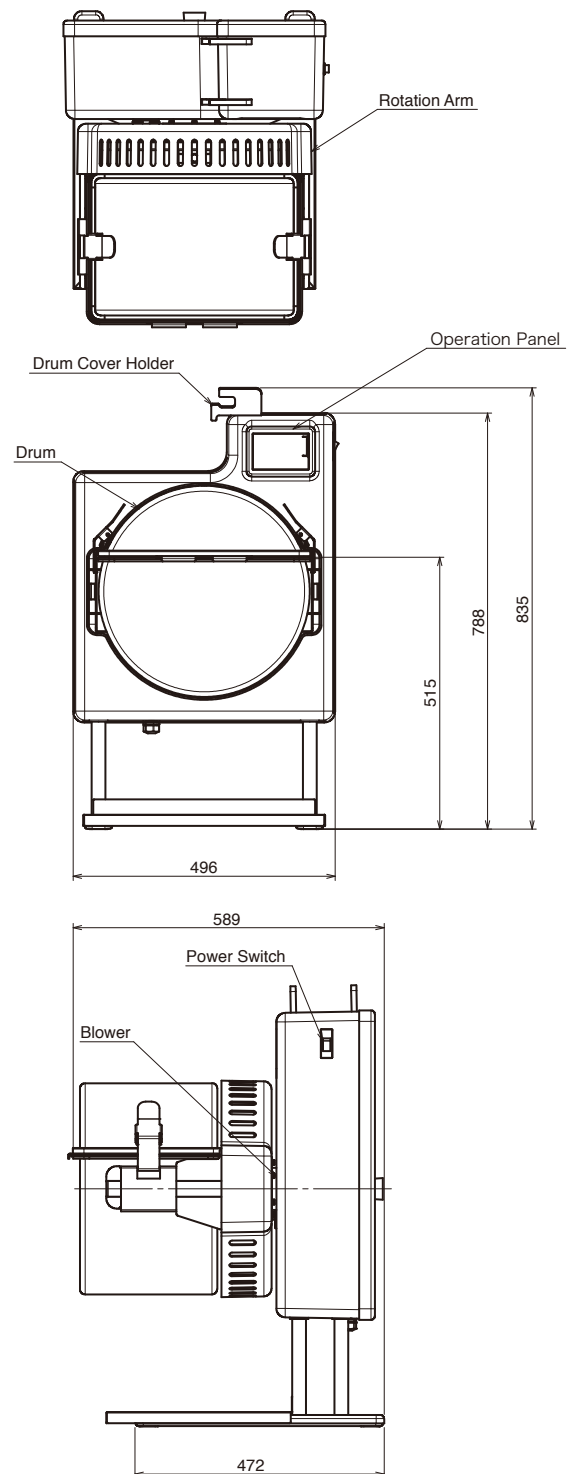

* Designs and specifications subject to change without notice.

* Please follow the directions in the operations manual when handling the machine.

* While capacity expresses the machine's performance capabilities, it is predicated upon the machine being operated correctly.



Suzumo Machinery Co., Ltd.

Overseas Business Division

2-23-2, Toyotamakita, Nerima-ku,

Tokyo 176-0012, Japan

Tel. +81 3-3993-1407 Fax. +81 3-3993-1756

e-mail overseas@suzumo.co.jp

URL <http://www.suzumokikou.com>

< Contact in North America >

Suzumo International Corporation

379 Van Ness Ave., Suite 1406

Torrance, California 90501, U.S.A.

Tel. +1 310-328-0400

Fax. +1 310-328-2700

e-mail sic@suzumokikou.com